



LIS3L02AS4

INERTIAL SENSOR: 3Axis - 2g/6g LINEAR ACCELEROMETER

PRODUCT PREVIEW

- 2.4V TO 5.25V SINGLE SUPPLY OPERATION
- THE SENSITIVITY IS ADJUSTED WITH A TOTAL ACCURACY OF $\pm 10\%$
- THE OUTPUT VOLTAGE, OFFSET, SENSITIVITY AND TEST VOLTAGE ARE RATIO-METRIC TO THE SUPPLY VOLTAGE
- DEVICE SENSITIVITY IS ON-CHIP FACTORY TRIMMED
- EMBEDDED SELF TEST
- HIGH SHOCK SURVIVABILITY

DESCRIPTION

The LIS3L02AS4 is a tri-axis linear accelerometer that includes a sensing element and an IC interface able to take the information from the sensing element and to provide an analog signal to the external world.

The sensing element, capable to detect the acceleration, is manufactured using a dedicated process called THELMA (Thick Epi-Poly Layer for Microactuators and Accelerometers) developed by ST to produce inertial sensors and actuators in silicon.

The IC interface instead is manufactured using a CMOS process that allows high level of integration to design a dedicated circuit which is trimmed to better match the sensing element characteristics.

The LIS3L02AS4 has a user selectable full scale of 2g, 6g and it is capable of measuring accelerations

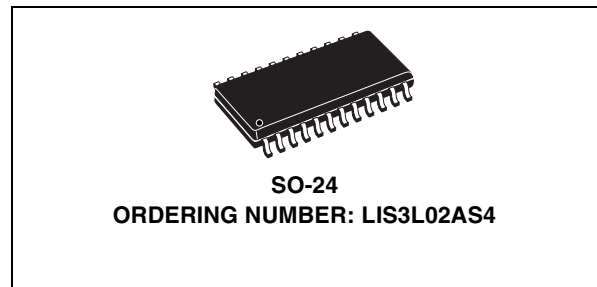

over a maximum bandwidth of 4.0 KHz for the X and Y axis and 2.5 KHz for the Z axis. The device bandwidth may be reduced by using external capacitances. A self-test capability allows the user to check the functioning of the system.

The LIS3L02AS4 is available in plastic SMD package and it is specified over a temperature range extending from -40°C to $+85^{\circ}\text{C}$.

The LIS3L02AS4 belongs to a family of products suitable for a variety of applications:

- Antitheft systems
- Inertial navigation
- Virtual reality input devices
- Vibration Monitoring, recording and compensation
- Appliance control
- Robotics

BLOCK DIAGRAM

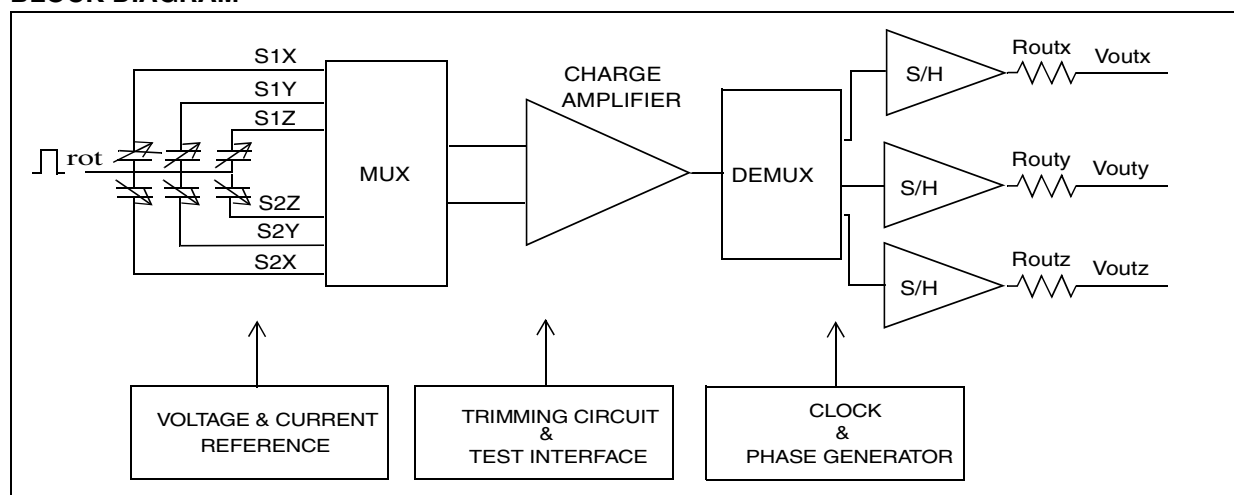

LIS3L02AS4

PIN DESCRIPTION

N°	Pin	Function
1 to 5	NC	Internally not connected
6	GND	0V supply
7	Vdd	Power supply
8	Vouty	Output Voltage
9	ST	Self Test (Logic 0: normal mode; Logic 1: Self-test)
10	Voutx	Output Voltage
11	PD	Power Down (Logic 0: normal mode; Logic 1: Power-Down mode)
12	Voutz	Output Voltage
13	FS	Full Scale selection (Logic 0: 2g Full-scale; Logic 1: 6g Full-scale)
14-15	Reserved	Leave unconnected or connect to Vdd
16	Reserved	Connect to Vdd or ground
17	Reserved	Leave unconnected or connect to Vdd
18	Reserved	Leave unconnected or connect to ground
19 to 24	NC	Internally not connected

PIN CONNECTION (Top view)

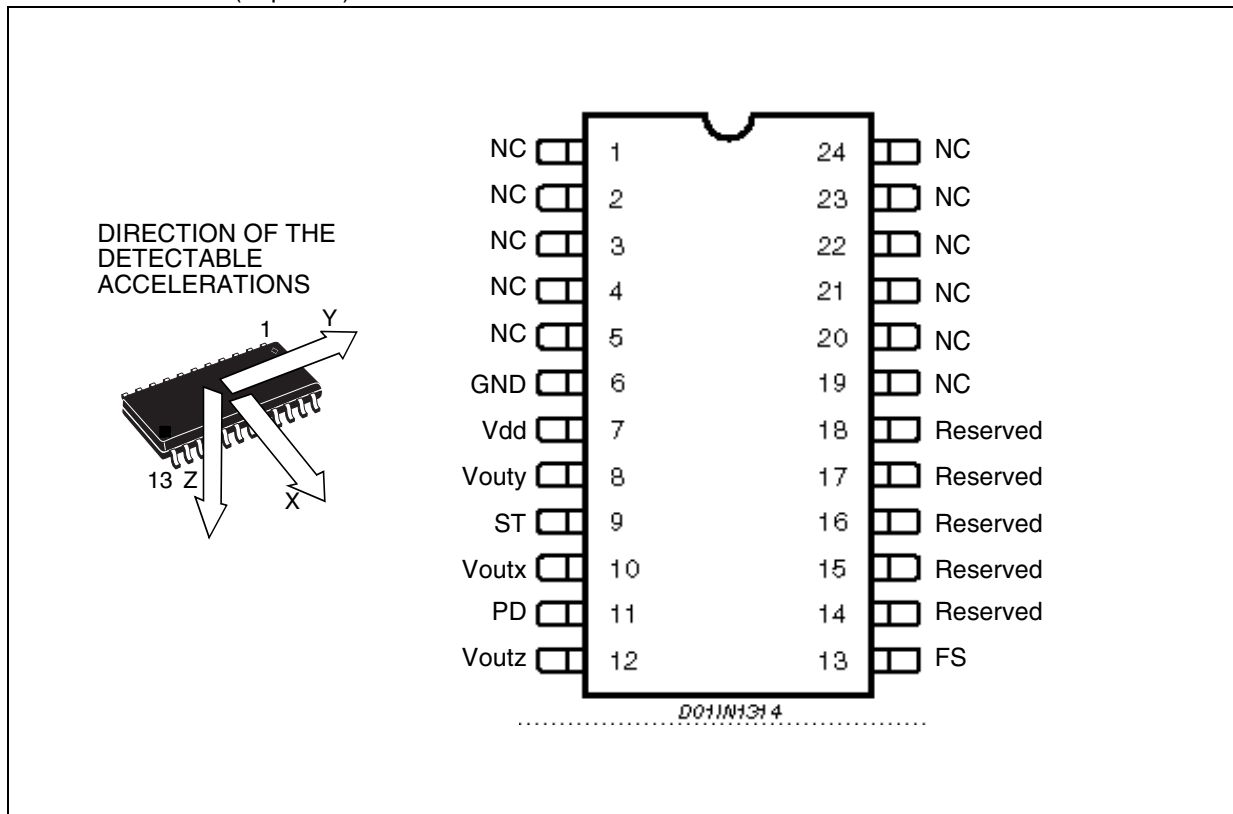

ELECTRICAL CHARACTERISTICS (Temperature range -40°C to +85°C)

All the parameters are specified @ Vdd=3.3V and T=25°C unless otherwise noted

Symbol	Parameter	Test Condition	Min.	Typ. ¹	Max.	Unit
Vdd	Supply voltage		2.4		5.25	V
Idd	Supply current			850		μA
Voff	Zero-g level	T = 25°C	Vdd/2-18%	Vdd/2	Vdd/2+18%	V
Ar	Acceleration range ²	T = 25°C FS pin connected to GND	±1.8	±2.0	±2.2	g
		T = 25°C FS pin connected to Vdd		±6.0		g
So	Sensitivity ratiometric to Vdd	T = 25°C Full-scale = 2g	Vdd/5-10%	Vdd/5	Vdd/5+10%	V/g
		T = 25°C Full-scale = 6g	Vdd/15-10%	Vdd/15	Vdd/15+10%	V/g
NL	Non Linearity	Best fit straight line X, Y axis Full-scale = 2g		±1		% FS
		Best fit straight line Z axis Full-scale = 2g		±3		% FS
fuc	Sensing Element Resonant Frequency	X, Y axis		4.0		KHz
		Z axis		2.5		KHz
an	Acceleration noise density	Vdd=5V Full-scale = 2g		50		μg/√Hz
Vt	Self test output voltage	T = 25°C Vdd=3.3V		33		mV
		T = 25°C Vdd=5V		115		mV
Vst	Self test input	Logic 0 level	0		0.8	V
		Logic 1 level	2.2		Vdd	V
Rout	Output impedance			100		kΩ
Cload	Capacitive load drive ³		320			pF

Notes: 1. Typical specifications are not guaranteed

2. Guaranteed by wafer level test and measurement of initial offset and sensitivity

3. Bandwidth=1/(2*π*100KΩ*Cload)

ABSOLUTE MAXIMUM RATING

Stresses above those listed as “absolute maximum ratings” may cause permanent damage to the device. This is a stress rating only and functional operation of the device under these conditions is not implied. Exposure to maximum rating conditions for extended periods may affect device reliability.

Symbol	Ratings	Maximum Value	Unit
V _{DD}	Supply voltage	-0.3 to 6	V
V _{IN}	Input voltage on any control pin (FS, PD, ST)	V _{SS} -0.3 to V _{DD} +0.3	V
A _{POW}	Acceleration (Any axis, Powered, V _{DD} =3.3V)	3000g for 0.5 ms	
A _{UNP}	Acceleration (Any axis, Unpowered)	3000g for 0.5 ms	
T _{OP}	Operating Temperature Range	-40 to +85	°C
T _{STG}	Storage Temperature Range	-40 to +105	°C

1 FUNCTIONALITY

The LIS3L02AS4 is a low-cost, analog output three-axis linear accelerometer packaged in SO24 package. The complete device includes a sensing element and an IC interface able to take the information from the sensing element and to provide an analog signal to the external world.

1.1 Sensing element

The THELMA process is utilized to create a surface micro-machined accelerometer. The technology allows to carry out suspended silicon structures which are attached to the substrate in a few points called anchors and free to move on a plane parallel to the substrate itself. To be compatible with the traditional packaging techniques a cap is placed on top of the sensing element to avoid blocking the moving parts during the molding phase.

The equivalent circuit for the sensing element is shown in the below figure; when a linear acceleration is applied, the proof mass displaces from its nominal position, causing an imbalance in the capacitive half-bridge. This imbalance is measured using charge integration in response to a voltage pulse applied to the sense capacitor.

The nominal value of the capacitors, at steady state, is few pF and when an acceleration is applied the maximum variation of the capacitive load is few tenth of pF.

Figure 1. Equivalent electrical circuit

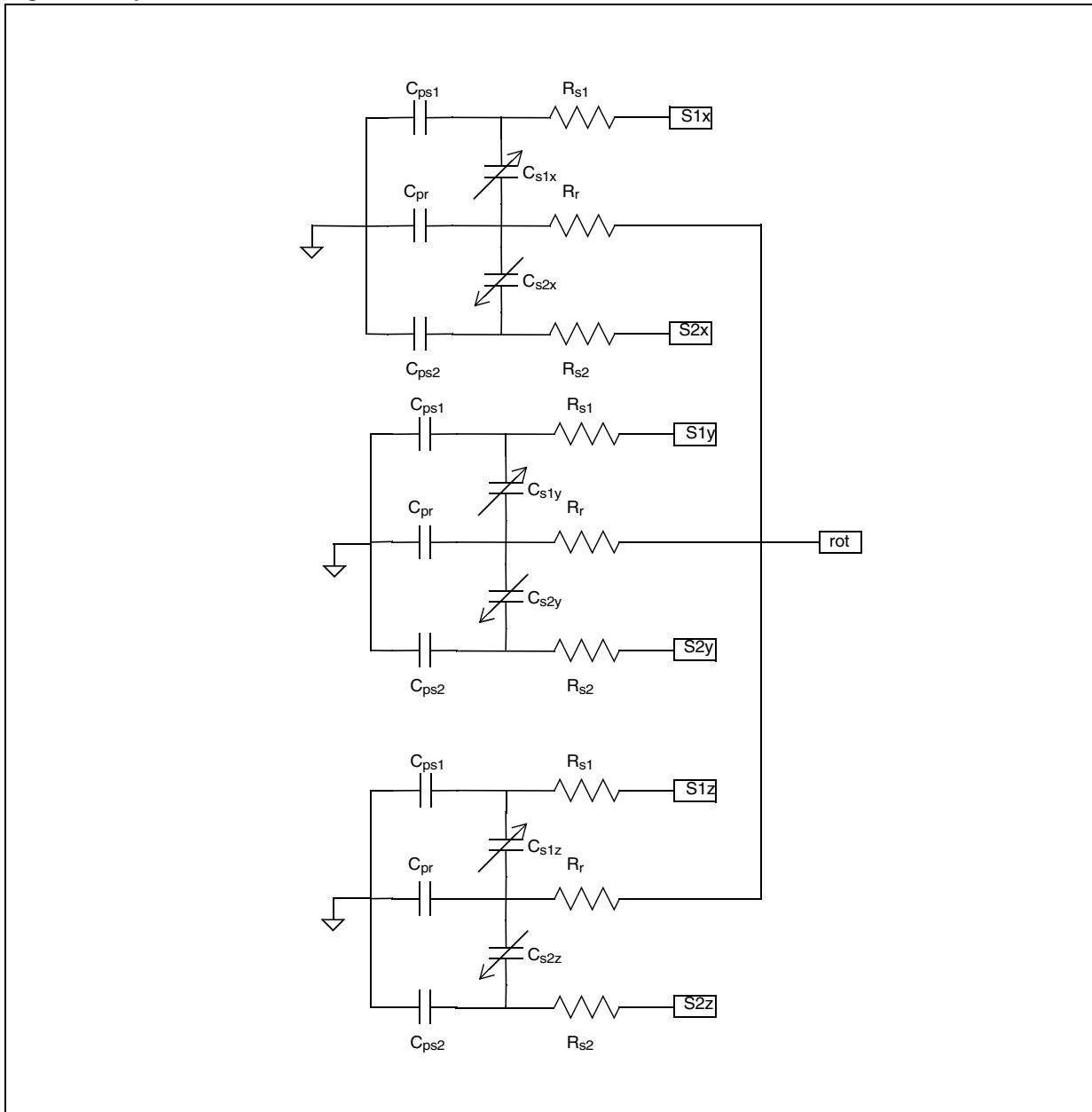

1.2 IC Interface

The complete signal processing uses a fully differential structure, while the final stage converts the differential signal into a single-ended one to be compatible with the external world.

The first stage is a low-noise capacitive amplifier that implements a Correlated Double Sampling (CDS) at its output to cancel the offset and the $1/f$ noise. The produced signal is then sent to three different S&Hs, one for each channel, and made available to the outside.

The low noise input amplifier operates at 200 kHz while the three S&Hs operate at a sampling frequency of 66 kHz. This allows a large oversampling ratio, which leads to in-band noise reduction and to an accurate output waveform.

All the analog parameters (output offset voltage and sensitivity) are ratiometric to the voltage supply. Increasing

or decreasing the voltage supply, the sensitivity and the offset will increase or decrease linearly. The feature provides the cancellation of the error related to the voltage supply along an analog to digital conversion chain.

1.3 Factory calibration

The IC interface is factory calibrated to provide to the final user a device ready to operate. The parameters which are trimmed are: gain, offset, common mode and internal clock frequency.

The trimming values are stored inside the device by a non volatile structure. Any time the device is turned on, the trimming parameters are downloaded into the registers to be employed during the normal operation thus allowing the final user to employ the device without any need for further calibration.

DIM.	mm			inch		
	MIN.	TYP.	MAX.	MIN.	TYP.	MAX.
A	2.35		2.65	0.093		0.104
A1	0.10		0.30	0.004		0.012
A2			2.55			0.100
B	0.33		0.51	0.013		0.0200
C	0.23		0.32	0.009		0.013
D	15.20		15.60	0.598		0.614
E	7.40		7.60	0.291		0.299
e		1.27			0,050	
H	10.0		10.65	0.394		0.419
h	0.25		0.75	0.010		0.030
k	0° (min.), 8° (max.)					
L	0.40		1.27	0.016		0.050

OUTLINE AND MECHANICAL DATA

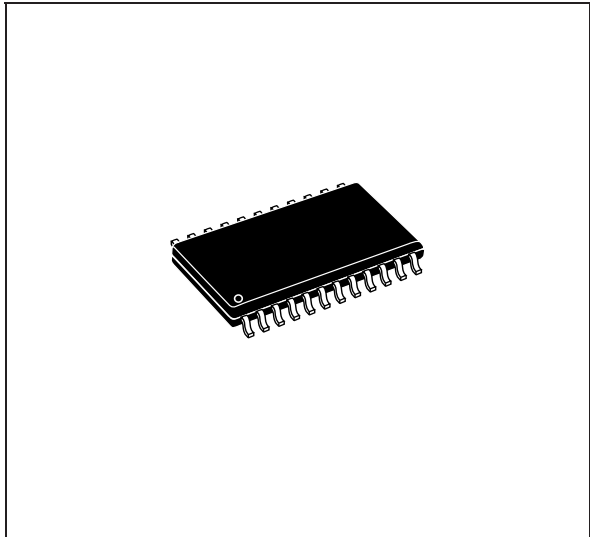

SO24

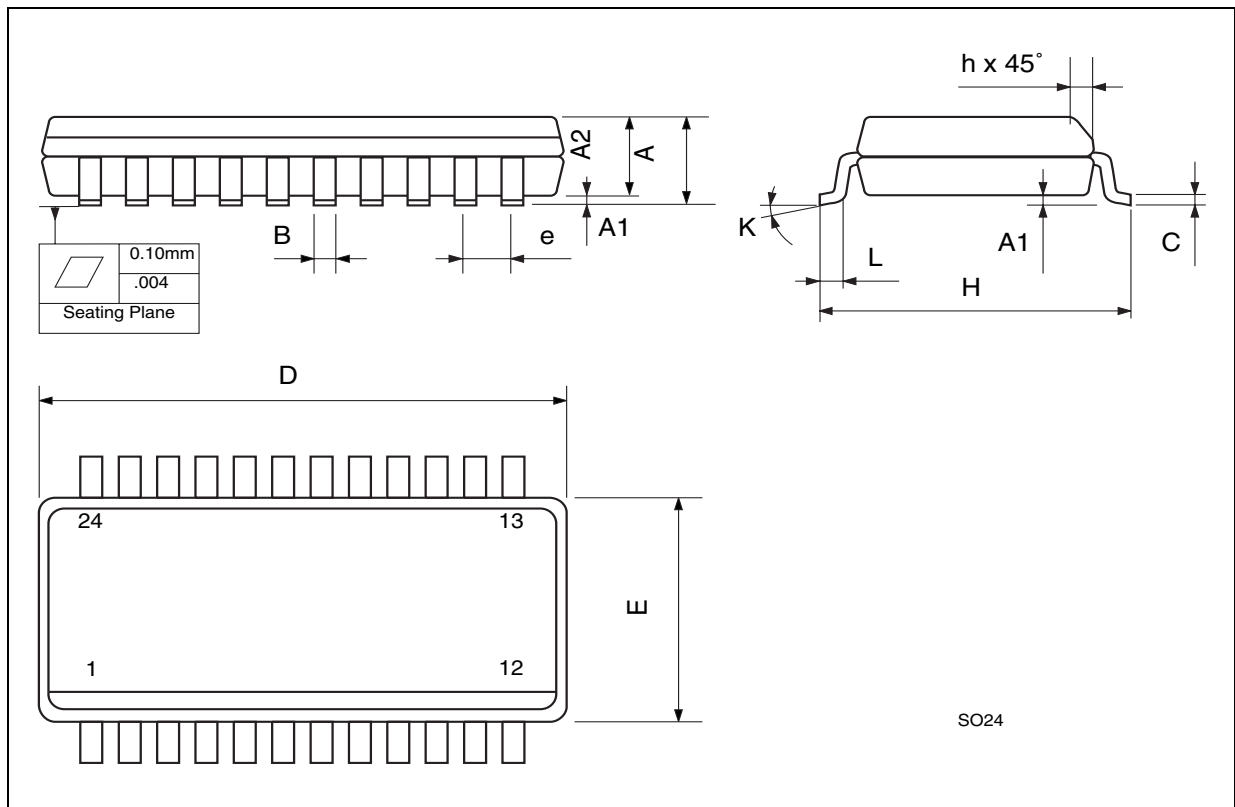

Information furnished is believed to be accurate and reliable. However, STMicroelectronics assumes no responsibility for the consequences of use of such information nor for any infringement of patents or other rights of third parties which may result from its use. No license is granted by implication or otherwise under any patent or patent rights of STMicroelectronics. Specifications mentioned in this publication are subject to change without notice. This publication supersedes and replaces all information previously supplied. STMicroelectronics products are not authorized for use as critical components in life support devices or systems without express written approval of STMicroelectronics.

The ST logo is a registered trademark of STMicroelectronics.
All other names are the property of their respective owners

© 2004 STMicroelectronics - All rights reserved

STMicroelectronics GROUP OF COMPANIES

Australia - Belgium - Brazil - Canada - China - Czech Republic - Finland - France - Germany - Hong Kong - India - Israel - Italy - Japan -
Malaysia - Malta - Morocco - Singapore - Spain - Sweden - Switzerland - United Kingdom - United States
www.st.com

This datasheet has been download from:

www.datasheetcatalog.com

Datasheets for electronics components.